

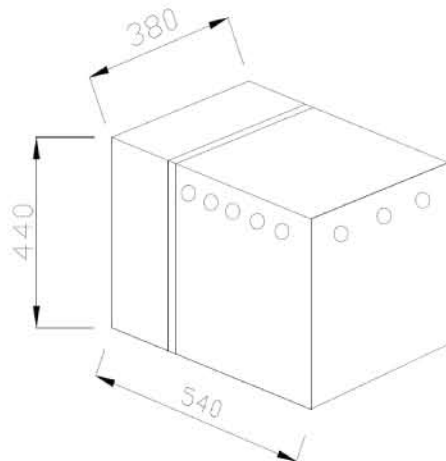

IMPIANTO OCEANO I. 28 INOX SOTTOBANCO ACQUA

OCEANO I.28 STAINLESS STEEL REMOTE COOLER

CARATTERISTICHE TECNICHE	
BANCO GHIACCIO (ICE BANK)	
COMPRESSORE COMPRESSOR	1/4 HP POT
CAPACITA' REFRIGERANTE COOLING POWER	461 W
POTENZA ASSORBITA INPUT POWER	291 W
TENSIONE VOLTAGE	230 V / 50 HZ
BANCO GHIACCIO ICE BANK	11 KG
LITRI VASCA WATER TANK CAPACITY	25 LT
LITRI EROGATI LITERS CHILLED	100 LT/H
CAPACITA' CARBONATORE CARBONATOR CAPACITY	1,24 LT
POMPA DI CARBONAZIONE CARBONATOR PUMP	200 LT/H
EROGAZIONE ACQUA	
FREDDO/TEMP. AMBIENTE/FRIZZANTE DISPENSED PRODUCTS	COLD - AMBIENT - CARBONATED WATER



**INOX 1/4 HP POT
ST.STEEL 1/4 HP**

CODICE	DESCRIZIONE
RV1511	IMP. OCEANO I.28 INOX SOTT. 1/4 HP B/G FRIZZ/FREDDA/TEMP. AMB. OCEANO I.28 STAINLESS STEEL COOLER 1/4HP ICE-BANK SPARKLING/COLD/AMBIENT WATER